

# ProFibre™ OPTICAL BREAKOUT CABLES

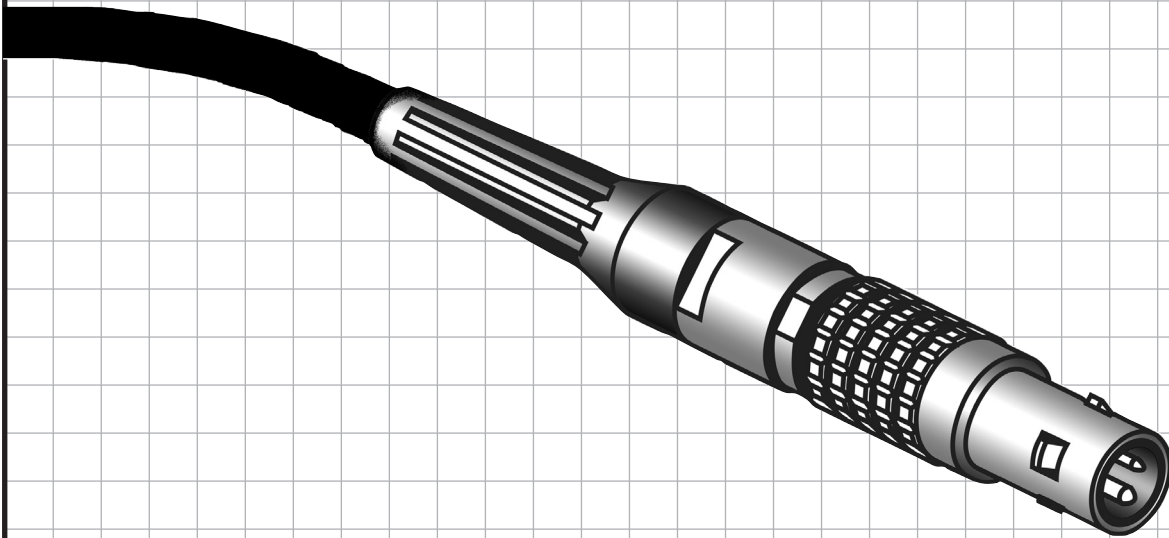

## THE WORLD'S MOST DURABLE FIBRE OPTIC CABLE

- Built to military tactical standards.
- PUR jacket material is flame retardant and offers abrasion, cut and chemical resistance.
- Highly flexible construction is easy to coil, yet resists kinking and protects fiber cores.
- Tight buffered design reduces field termination cost and installation time.
- Suitable for indoor and outdoor applications.
- Helical lay reduces fatigue failure after repeated coiling, for longer life expectancy.
- Splice loss eliminated.



### LOS ANGELES

10643 Glenoaks Blvd.  
Pacoima, CA 91331  
USA

Tel: +1 818.899.8818  
Fax: +1 818.899.8813

### LONDON

21 Armstrong Way  
Southall  
UB2 4SD England

Tel: +44 (0)20.8574.9700  
Fax: +44 (0)20.8574.9701

### NEW YORK

100 Asia Place  
Carlstadt, NJ 07072  
USA

Tel: +1 201.896.8600  
Fax: +1 201.896.8601

### BEIJING

No. 309, Building 6  
Sanlitun Nanlu  
Chaoyang District  
Beijing, China 100027

Tel: +86 10.8492.1587  
Fax: +86 10.8492.7635

### TORONTO

409 Saddle St. West  
Box 654, Durham  
Ontario N0G-1R0

Tel: +1 519.369.9990  
Fax: +1 519.369.9992

## Fiber Cross-Section Illustrations

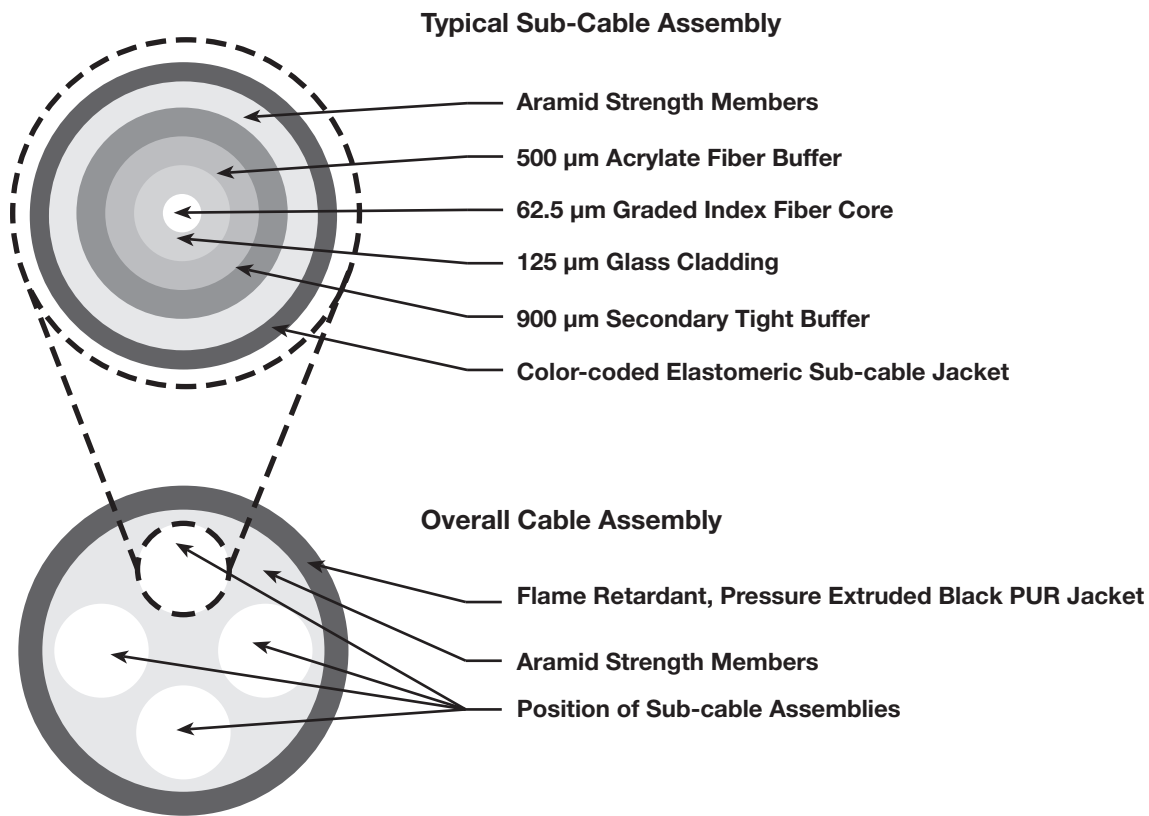

MECHANICAL DATA	
Crush Resistance	2200 N/cm
Impact Resistance	1500 Impacts
Flex Resistance	2000 Cycles
Minimum Bending Radius	15 x O.D. for Installation 7 x O.D. for Long Term
Tensile Load Rating	Short Term- 2200 N (490 lbs.) Long Term- 550 N (120 lbs.)
THERMAL DATA	
Operating Temperature	-55°C to +105°C
Storage Temperature	-70°C to +105°C

TRANSMISSION DATA	
Attenuation	
at 850nm	3.0 db / km max.
at 1300nm	1.0 db / km max
Bandwidth	
at 850nm	200 MHz / km min.
at 1300nm	500 MHz / km min.
DIMENSIONS	
Overall Diameter	2-Core - 6.8 mm 4-Core - 7.2 mm
Weight	2-Core - 34 Kg/Km (23 lbs./mft.) 4-Core - 45 Kg/Km (30 lbs./mft.)