

ProCan III™

CE

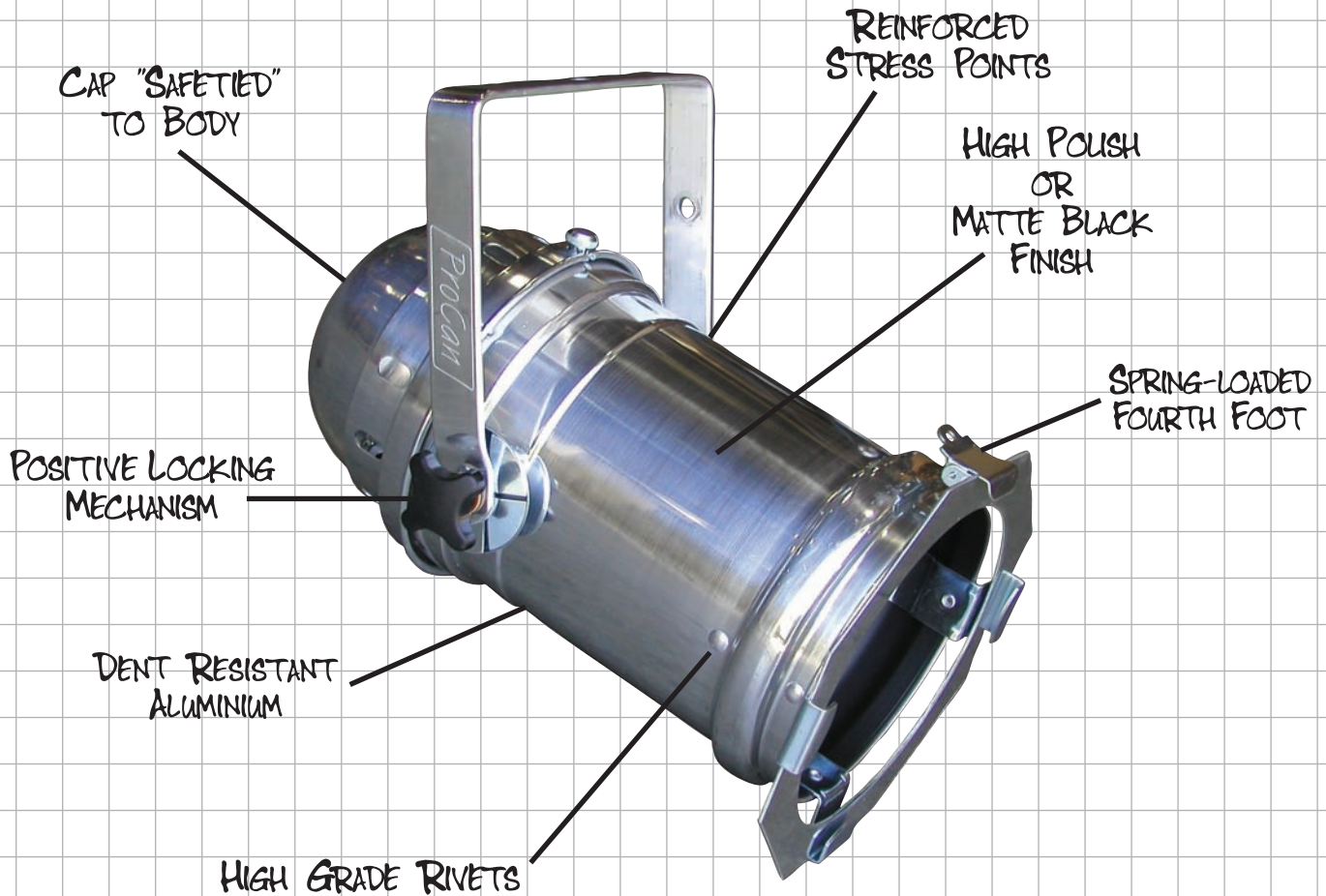

PAR CANS FOR TOURING USE...

ProCan™

PROFESSIONAL LIGHTING EQUIPMENT



LOS ANGELES

10643 Glenoaks Blvd.
Pacoima, CA 91331
USA

Tel: +1 818.899.8818
Fax: +1 818.899.8813

LONDON

21 Armstrong Way
Southall
UB2 4SD England

Tel: +44 (0)20.8574.9700
Fax: +44 (0)20.8574.9701

NEW YORK

100 Asia Place
Carlstadt, NJ 07072
USA

Tel: +1 201.896.8600
Fax: +1 201.896.8601

BEIJING

No. 309, Building 6
Sanlitun Nanlu
Chaoyang District
Beijing, China 100027

Tel: +86 10.8492.1587
Fax: +86 10.8492.7635

TORONTO

409 Saddle St. West
Box 654, Durham
Ontario N0G-1R0

Tel: +1 519.369.9990
Fax: +1 519.369.9992

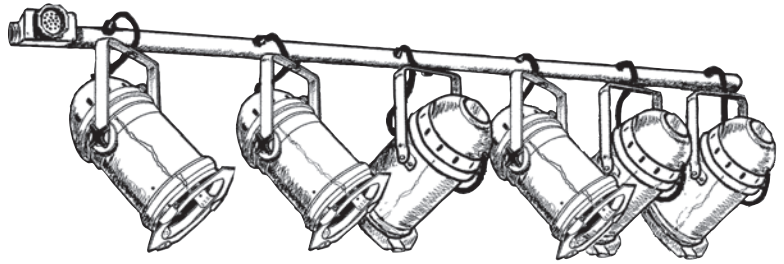

SAFETY

- Make sure that no mains cables rest in contact with fixture body.
- Yoke of fixture may be mounted to a lighting bar, hook clamp, TV spud, or any non-flammable surface using an M10 bolt.
- The mounting bolt and hand nut may be used to adjust and maintain fixture position. Tighten firmly when position is correct.
- Replace lamp if cracked or thermally deformed.
- Replace mesh screen if damaged or missing.
- Make sure that lamp can spin freely after fitting the retaining ring.
- Fixture is not rated for and must not be used in environments containing flammable or explosive materials.
- A safety cable must always be used to secure fixture to supporting framework.
- When barn doors are used, a safety cable must always be looped from the barn door frame to the fixture.
- When connecting to mains power supply, make sure that the fixture is properly earthed and that the supply is at the rated voltage for the lamp and observe the correct polarity.
- Maximum rated ambient temperature is 45° C.
- Maximum rated voltage is 250 volts.
- Nominal frequency is 50/60 Hertz.

LAMP REPLACEMENT

- Disconnect fixture from power supply and allow to cool.
- Lift cap retainer and remove cap.
- Disconnect lampholder or wires from lamp.
- Remove lamp retaining ring by squeezing bent ends together and lifting ring away.
- Remove old lamp and replace with new lamp.
- Refit lamp retaining ring below dimples, making sure lamp can rotate freely.
- Reconnect lampholder or wires.
- Refit cap making sure that wires and lamp adjuster allow free movement of lamp.
- Connect to power and re-focus as necessary.

WARNING - Disconnect from power before re-lamping.

CAUTION - Lamp may be very hot.

COMMON LAMP TYPES			
Lamp Type	Voltage	Wattage	Fuse Size
CP60 / 61 / 62	230V	1000W	5 Amp
CP86 / 87 / 88	230V	500W	3 Amp
FFN / FFP / FFR / FFS	120V	1000W	8 Amp
DYS (with Raylite Reflector)	120V	600W	5 Amp
500PAR64	120V	500W	4 Amp
4552	28V	250W	10 Amp
4559 / Q4559	28V	600W	25 Amp

Lampholder and wiring configuration varies.

DIMENSIONS (in millimetres)									
	A	B	C	D	E	F	G	H	I
PAR 64	425	260	470	356	222	241	203	254	78
PAR 64 Short	280	260	337	368	235	254	203	254	78
PAR 64 Floor Can	280	260	340	369	240	254	203	254	78
PAR 56	368	235	400	305	197	216	166	227	65
PAR 56 Short	260	230	295	305	191	221	166	227	65
PAR 56 Floor Can	266	230	310	320	206	229	166	227	65
PAR 36	350	170	370	248	156	141	110	164	N/A
PAR 36 Short	230	170	258	240	158	146	110	164	N/A

