

The Digital Festoon System

The Digital Festoon System is a radical re-think of conventional festoon lighting offering individual control of every lamp along a length of a standard festoon cable.

Traditional lighting festoons use lampholders attached to two-core cable. All of the lamps on one cable can be switched off, on or, if connected to a dimmer, faded up and down - but all at the same time and to the same level.

The Digital Festoon System uses the same two-core cable, but uses a patented data system to send both power and control data along this cable from the DFS power supply to the DFS lampholders. This allows each lamp along the festoon's length to be controlled and dimmed independently - without the need for any external dimmers. Each DFS power supply can drive up to 200 lamps along a cable length of up to 100m. Up to 500 power supplies can be interconnected, giving centralised, individual control of up to 100,000 lamps.

The Digital Festoon System can be controlled using standard DMX lighting consoles, or programmed using its own PC-based control software that includes a visualiser to aid effect programming. Once programmed, the PC can be removed to leave the DFS power supply to handle the show playback. Each power supply can store up to 30,000 lighting scenes and can play back up to twenty scenes per second - making possible long, non-repetitive, complex lighting effects that can either be incredibly fast and dynamic or smooth, slow and subtle.

Winner of a PLASA Award for Innovation on its launch at the 2004 PLASA Show, where the award judges commented that the system was "an innovative return to incandescent lighting," the Digital Festoon System has already proved its worth on projects ranging from outdoor events to concerts.

- A standard two-core festoon cable that carries 48V and data.
- Up to 200 lamps per 100 metre string. 500 strings can be linked via a serial cable between PSUs.
- This equates to individual control of up to 100,000 lamps.



Two core festoon cable supplies power to individually addressed lamp holders for maximum creativity

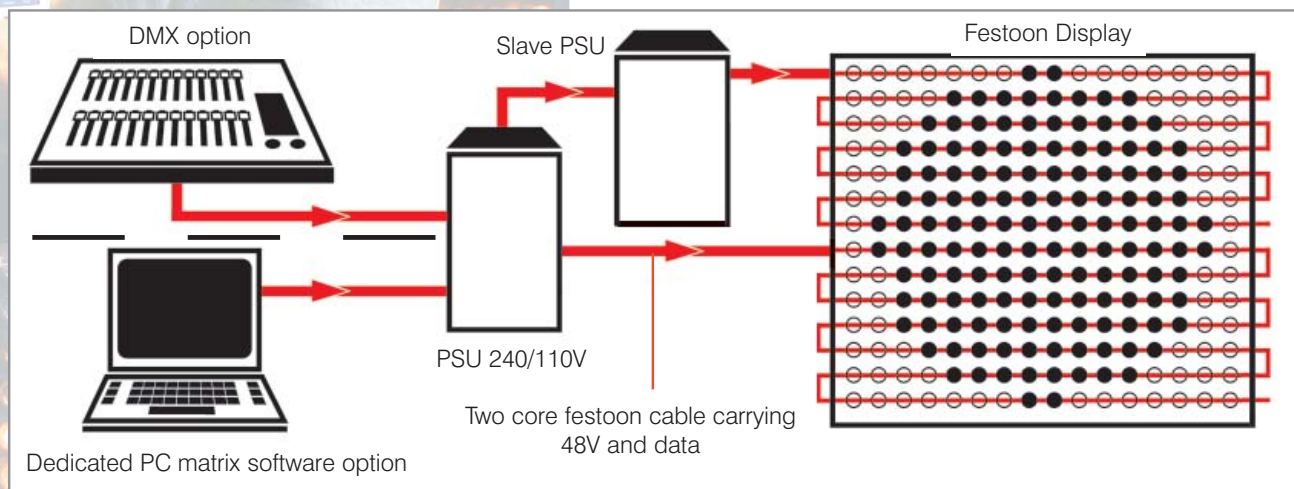

The Digital Festoon System

Specifications

DFS200RM Power Supply

- Control of up to 200 48V 5W lamps.
- Accepts removable memory card for permanent non volatile storage of custom lighting control sequences.
- Protection from lamp wiring faults.
- Lamp data updated every 0.05 seconds (20 times per second).
- RS232 input to upload program data from a PC or notebook.
- Any number of power supplies can be easily synchronized using a simple master/slave system via a two core cable between supplies.
- New Rackmount design with Mode select switch and clear operational indicators.
- One easily replaced PCB assembly for ease of repair.
- Full DMX operation.
- Remote start -stop control facility available.
- 110 / 230VAC input.
- Comprehensive self diagnostic system with fault indication via coded flashing indicator.
 - Internal fuse failure.
 - Output short circuit.
 - Memory card download active.
 - DMX Sync received.
 - Driver failure.
- CE approval as standard.
- UL approval pending.
- Full short circuit protection.

Memory Card

The memory card holds the user program for lamp sequence control. Up to 30,000 scenes can be stored in a single memory card. The memory card is programmed via a PC or laptop when fitted to the power supply. The memory card is easily removed and re fitted in case of power supply failure.

Lamp Unit

- IP67 rating for long term outdoor application.
- Drives standard 5W 48V Baton lamp.
- Includes lamp filament pre-heater to extend bulb life by typically 3-5 times.
- Easy connection/disconnection from festoon cable with no assembly tools required.
- Each lamp is addressed once inserted into the display, using the hand held programmer.
- Lamp address can be reprogrammed using the hand held programmer described below.
- Each lamp accepts four commands -
 - Lamp on
 - Lamp off
 - Lamp fade up (fade time 0.1 - 180 seconds).
 - Lamp fade down (fade time 0.1 - 180 seconds).
- Easy to fit - surface mount or through panel mounting clip.
- Protected against lamp contacts short circuit.

PC Software

DFS software allows you to program linear festoon as well as matrix patterns. The software includes a visualiser that allows you to run each separate sequence before you upload to the power supply. A library of effects can be built up for future use and a stock of standard patterns will be added to the software as it continues to be developed.

Once completed, the lamp control program is uploaded to the memory card in the power supply via a standard RS232 link.

Hand Held Programmer

The hand held programmer plugs into the lamp unit in place of the lamp. Once inserted the hand held programmer can program the lamp address.

The hand held programmer also verifies correct lamp unit operation.



Innovative lamp operation



Festoon in action



Demonstration at PLASA 2005

© TMB. All Rights Reserved. Specifications subject to change without notice. LITFESTOON-010406



LOS ANGELES

10643 Glenoaks Blvd.
Pacoima, CA 91331
USA

Tel: +1 818.899.8818
Fax: +1 818.899.8813

LONDON

21 Armstrong Way
Southall
UB2 4SD England

Tel: +44 (0)20.8560.9652
Fax: +44 (0)20.8560.1064

NEW YORK

100 Asia Place
Carlstadt, NJ 07072
USA

Tel: +1 201.896.8600
Fax: +1 201.896.8601

BEIJING

Unit 4, Blk 7, Shizipo
Dongzhimenwai
Dongcheng District
Beijing, China 100027

Tel: +86 10.6417.2286
Fax: +86 10.6415.9475

TORONTO

409 Saddler St. West
Box 654, Durham
Ontario N0G-1R0

Tel: +1 519.369.9990
Fax: +1 519.369.9992